

MODEL 7334  
REGULATED DC POWER SUPPLY  
OPERATION MANUAL

KIKUSUI ELECTRONICS CORP.

74.5.2.5.22

# Power Requirements of this Product

Power requirements of this product have been changed and the relevant sections of the Operation Manual should be revised accordingly.

(Revision should be applied to items indicated by a check mark )

Input voltage

The input voltage of this product is \_\_\_\_\_ VAC,  
and the voltage range is \_\_\_\_\_ to \_\_\_\_\_ VAC. Use the product within this range only.

Input fuse

The rating of this product's input fuse is \_\_\_\_\_ A, \_\_\_\_\_ VAC, and \_\_\_\_\_.

## WARNING

- To avoid electrical shock, always disconnect the AC power cable or turn off the switch on the switchboard before attempting to check or replace the fuse.
- Use a fuse element having a shape, rating, and characteristics suitable for this product. The use of a fuse with a different rating or one that short circuits the fuse holder may result in fire, electric shock, or irreparable damage.

AC power cable

The product is provided with AC power cables described below. If the cable has no power plug, attach a power plug or crimp-style terminals to the cable in accordance with the wire colors specified in the drawing.

## WARNING

- The attachment of a power plug or crimp-style terminals must be carried out by qualified personnel.

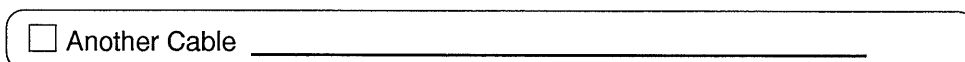

## C O N T E N T S

	Page
1. INTRODUCTION	3
2. SPECIFICATIONS	4
3. DESCRIPTION OF PANEL	6
3-1 Front Panel	6
3-2 Back Panel	7
4. OPERATION	8
4-1 Single, Series and Parallel Operations	8
4-2 Cautions regarding installation place	12
4-3 Overshoot of output voltage	12
4-4 Voltage Drop at Ammeter	12
4-5 Current Limit Circuit	12
5. MAINTENANCE	14
5-1 0V ADJ	14
5-2 Maximum voltage ADJ	14

## 1. INTRODUCTION

The Kikusui Electronics Model 7334 is a series-type Regulated DC Power Supply employing transistors and varying voltage continuously in the range 1V - 60V by its double-type variable resistance. It has a maximum output current of 0.5A. It is a compact and light power supply provided with a voltmeter and an ammeter on its panel.

If an overload phenomenon develops or a short-circuiting accident occurs, the output current limit circuit will work positively. The limit current can be set continuously in a range 10% - 100% of the maximum rated current and it can be employed as a constant-current power supply.

The unit can be operated in series or parallel.

## 2. SPECIFICATIONS

Line	----- V 50/60 Hz
Power consumption full load	Approx. 65 VA
Ambient temperature	40°C max.
Dimensions	106W x 145H x 301D mm
(Max.)	111W x 158H x 355D mm
Weight	Approx. 4.7 kg
Accessories	Short Bar 1 Operation Manual 1

### OUTPUT

Terminals	Red, white and black colors: arranged in an equilateral triangle at intervals of 19 mm.
Polarity	Positive or Negative
Floating voltage	$\pm$ 200V max.
Voltage	1 - 60V Continuously variable
Current	0.5A
Ripple	3mVp-p
Regulation	10mV against a fluctuation of $\pm$ 10% line voltage  10mV against a load fluctu- ation of 1 - 60V, 0 - 0.5A
Current limit (constant current automatic crossover type)	0.05A - 0.5A Continuously variable



### 3. DESCRIPTION FOR PANEL

#### 3-1 Front Panel

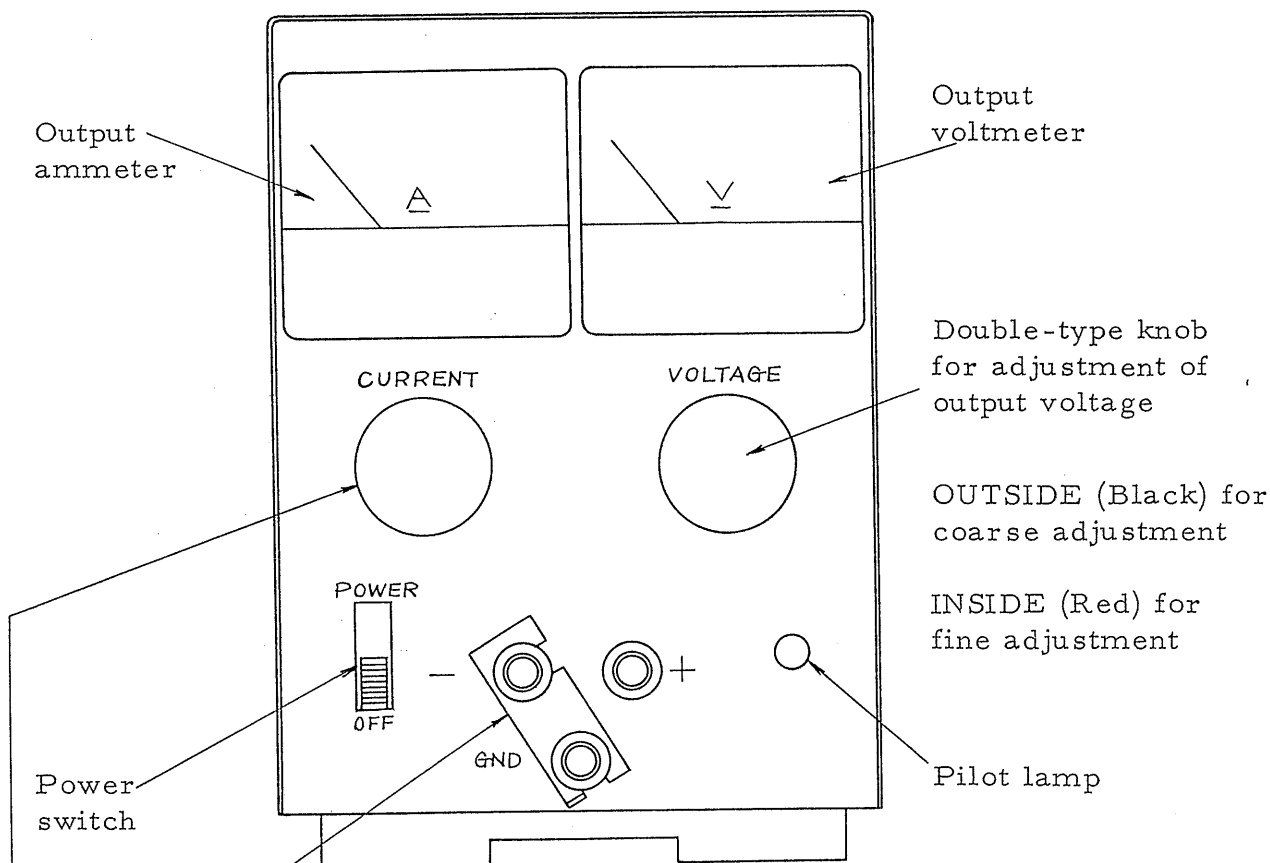

Fig. 1

#### OUTPUT TERMINAL

The plus or minus terminal is usually attached to the GND terminal and connected electrically to the chassis/panel by means of the attached short bar. It can be worked with DC bias current. (Refer to Item FLOATING VOLTAGE of the SPECIFICATIONS for the details.)

#### CURRENT LIMIT KNOB

Output current is limited in a range 10% - 100% of the maximum rated current. It can be used as a constant current power supply in the said range.

3-2 Back Panel

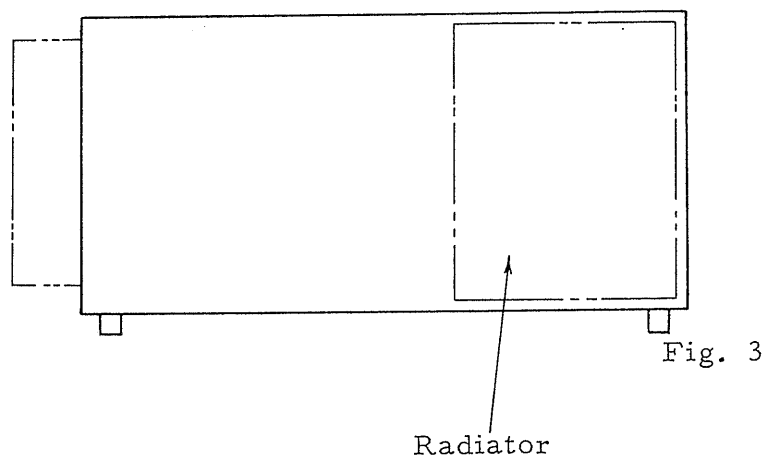
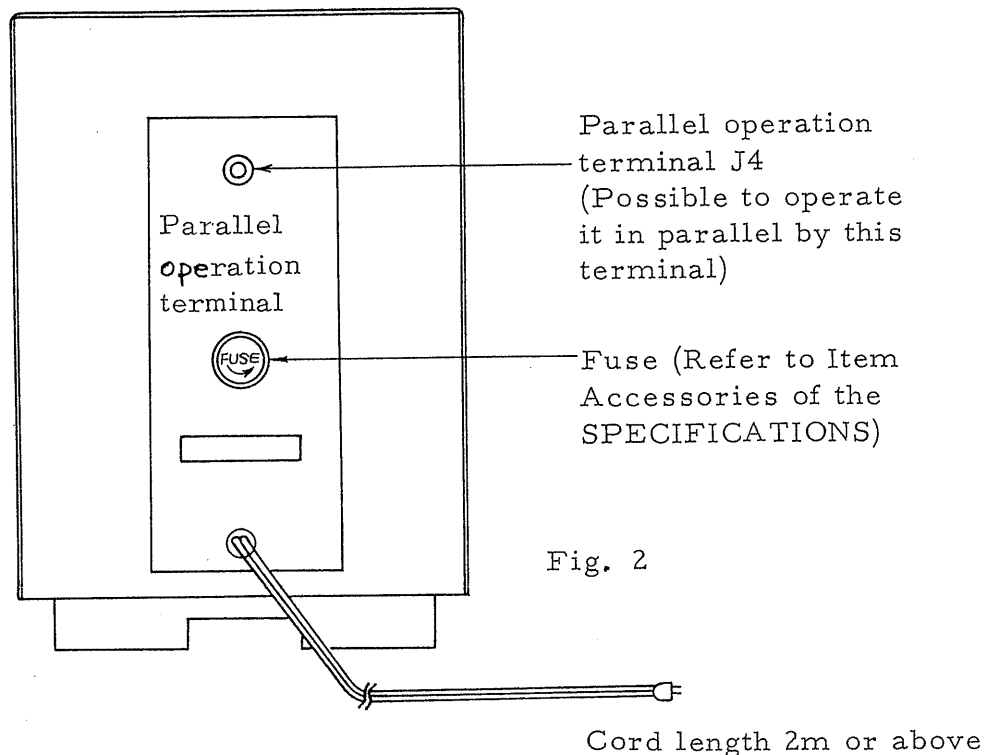

Pay attention to the state of ventilation at the radiator when the unit is used with current in the vicinity of maximum value and with low voltage.



#### 4. OPERATION

##### 4-1 Single, series and parallel operation

###### Single operation

Use the unit as it is for single operation.

###### Series operation

When more than 2 units are connected in series, higher voltage than that for 1 unit operation will be available. In this case, the voltage of any terminal must not exceed the floating voltage rated against the panel/chassis.

In series operation of 2 units, you may utilize a voltage twice the rated one and the rated current for 1 unit operation.

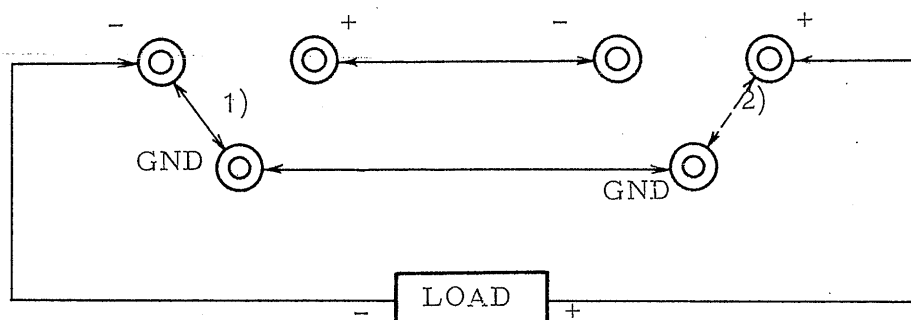

Wiring must be executed as indicated below for connection of GND TERMINAL.

- 1) Connect as shown with the line in Fig. 4 in the case of minus grounding.
- 2) Connect as shown with the dotted line in Fig. 4 in the case of plus grounding.

Be sure to avoid grounding the GND terminal in a different polarity.

### Protection against overload in series operation

If an overload phenomenon should develop when more than 2 POWER supplies are operated in series, output voltage of one of the units will be given, in the reverse direction, to the other unit of which the protection circuit has already worked, resulting in damage of its series control element. In order to prevent its being damaged, the diode has been connected between the output terminals of the respective POWER supply units. (Patent No. 308280)

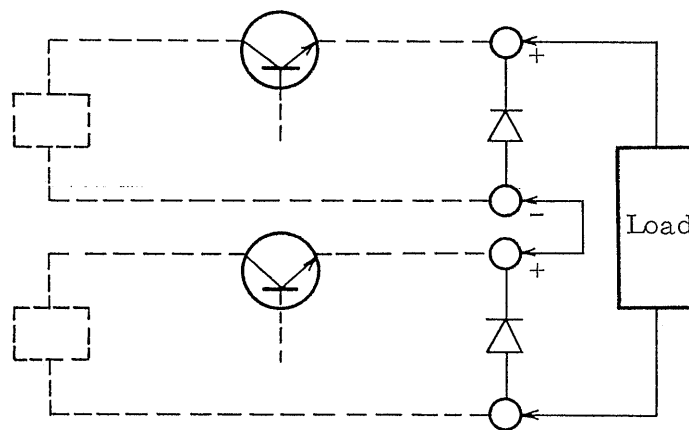

Fig. 5

### Parallel operation

Operate as indicated below when utilizing current twice the rated one by operating 2 units of the machine in parallel.

Be sure to turn off the POWER switch before arranging the wiring for this purpose.

In parallel operation, one of the 2 units serves as "master" unit and the other, as "slave" unit. Output voltage and output current are set at the "master" unit.

- 1) Remove the perforated plate of the "slave" unit and turn the slide switch in the print board from "MASTER" to "SLAVE".
- 2) Connect the J4 of the "slave" unit to the parallel operation terminal J4 located at the back of the "master" unit.
- 3) Turn fully the CURRENT knob of the "slave" unit to the "Maximum Current" position, i. e. turn it fully in the clockwise direction and also turn the VOLTAGE knob to the MAXIMUM position.
- 4) Replace the cover of the "slave" unit and turn on the POWER switch. Voltage and current may be varied optionally by the "master" unit.

The output current limit may be selected optionally in a range 10% - 100% of the value twice the maximum rated one.

Minus or plus earthing must be provided for both the "master" and "slave" units by means of the short bar. The same polarity must be earthed both in "master" and "slave" units. (Refer to Fig. 6 for the details.)

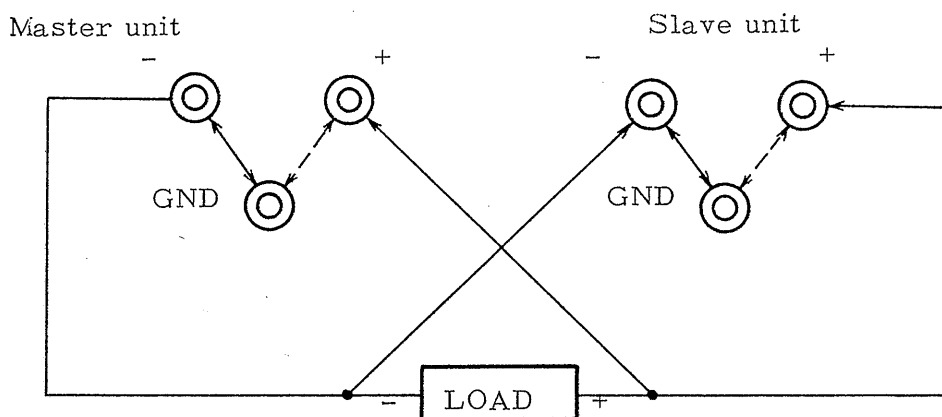

Fig. 6

The maximum number of parallel operation units of this model is only 2. This model cannot, in principle, be operated in parallel with other models.

Pay attention to the fact that when the POWER switch is turned on with the slide switch on the print board positioned at SLAVE, no output will be induced.

Fig. 6 shows the usable limit for series and parallel operation of 2 units.

Fig. 7

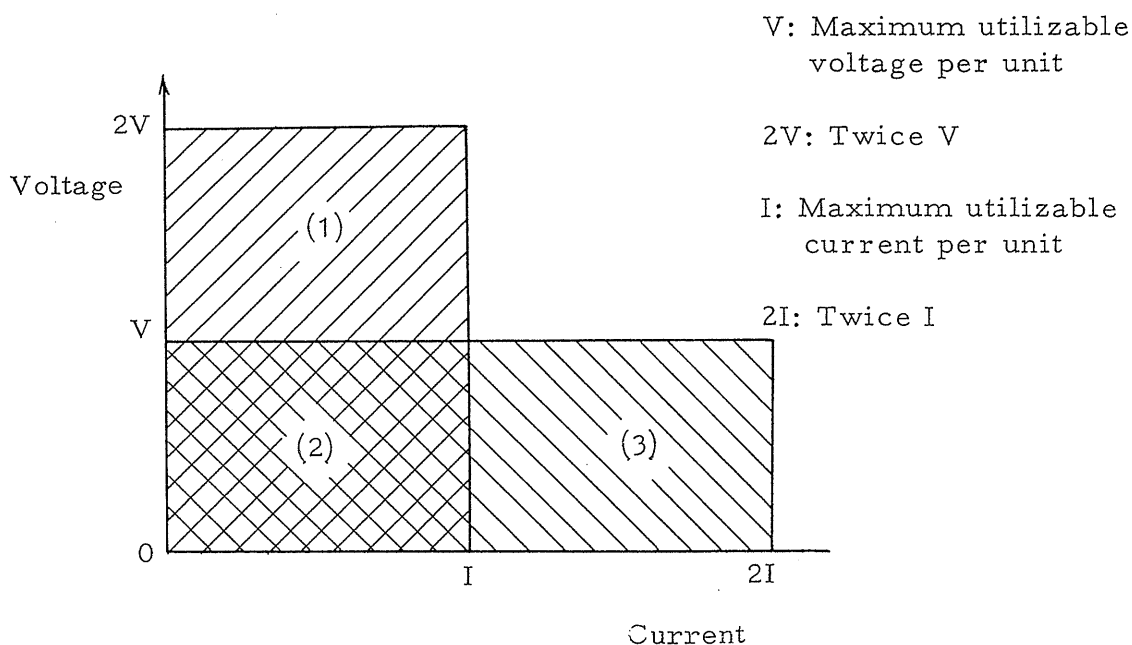

- Single operation.....Within the limit of (2)
  - Series operation.....Within the limit of (1) + (2)
  - Parallel operation.....Within the limit of (2) + (3)
- Single, series and parallel operation can be carried out as described hereabove.

#### 4-2 Cautions regarding installation place

Be sure to avoid, as far as possible, using the unit in a place where the ambient temperature exceeds 40°C.

When ventilation is restricted or the unit is exposed to the direct rays of the sun or radiation heat emitted from other heat sources, limit appropriately the continuous maximum output current.

90% - 110% of the rated voltage is the line voltage range in which the unit works positively and safely.

#### 4-3 Overshoot of output voltage

No voltage bigger than the set value is induced between output terminals when the POWER switch is turned on or off.

#### 4-4 Voltage drop of ammeter

The voltage drop of the output ammeter is circuit compensated.

#### 4-5 Current limit circuit

In order to prevent the series control element and output ammeter being damaged when the output terminal is short-circuited, the unit has been provided with a current control circuit which works electronically and positively to prevent a bigger current than the rated value being given.

The output limit current can be varied continuously at option in a range 10% - 100% of the maximum rated value.

When the output current reaches the set value, the unit serves

as a constant current power supply.

When the output current drops lower than the set value, the unit reverts automatically to serving continuously as a constant voltage power supply.

(Refer to Fig. 8 for the details.)

Fig. 8

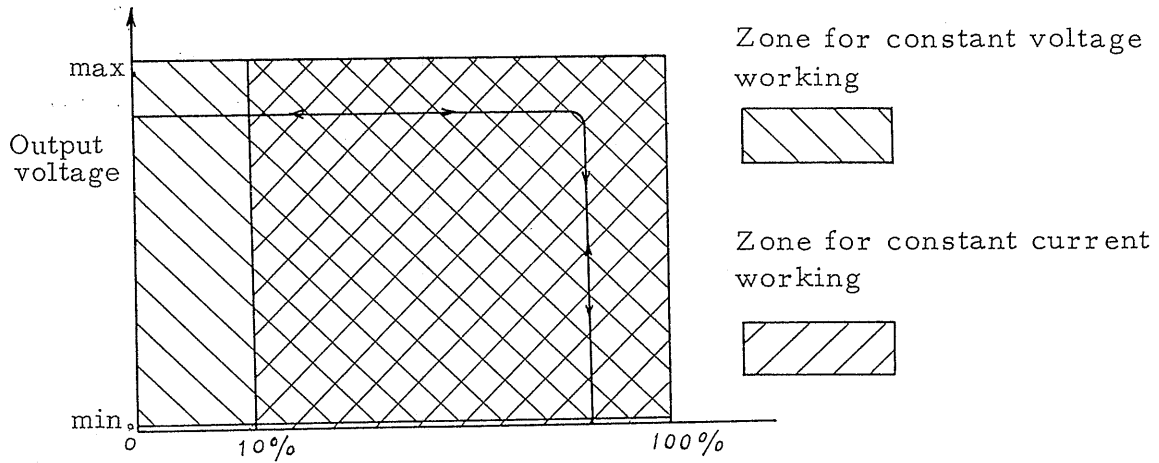

## 5. MAINTENANCE

When defective parts have been exchanged for new ones or the output voltage is not correct, it will be necessary to make the following adjustment.

### 5-1 0V ADJ

Adjust the semi-fixed resistor in the print board (copper foiled one) i. e. the semi-fixed resistor of (1) in Fig. 9 in such a way that the voltage between output terminals is 0V with the voltage adjustment knob on the panel turned fully counterclockwise.

The output voltage can thus be adjusted with an accuracy of  $\pm 0.5V$ .

### 5-2 Maximum voltage ADJ

Adjust the semi-fixed resistor in the board (semi-fixed resistor provided with numerous parts) i. e. the semi-fixed resistor of (2) in Fig. 9, so that the output terminal voltage is at the maximum rated value the voltage adjustment knob on the panel being turned fully clockwise (when fine adjustment knob is provided, with the knob turned almost to the central position).

Repeat the aforementioned adjustment several times.

